

# SanRex TRIACS

| $I_{T(RMS)}$ [A]                       | <b>16amp</b><br>( $T_c=96^\circ\text{C}$ )<br>Harmetic | <b>16amp</b><br>( $T_c=82^\circ\text{C}$ )<br>Harmetic<br>Isolated | <b>16amp</b><br>( $T_c=83^\circ\text{C}$ )<br>Mold<br>Isolated | <b>25amp</b><br>( $T_c=88^\circ\text{C}$ )<br>Harmetic | <b>25amp</b><br>( $T_c=74^\circ\text{C}$ )<br>Harmetic<br>Isolated | <b>25amp</b><br>( $T_c=74^\circ\text{C}$ )<br>Mold<br>Isolated | <b>35amp</b><br>( $T_c=84^\circ\text{C}$ )<br>Harmetic | <b>35amp</b><br>( $T_c=62^\circ\text{C}$ )<br>Harmetic<br>Isolated |           |
|--|--|--|--|--|--|--|--|--|-----------|
| $V_{DRM}$<br>[V]                       | <b>200</b>   | SSG16C20   | SSG16C20Y  | TG16C20  | SSG25C20   | SSG25C20Y  | TG25C20  | SSG35C20   | SSG35C20Y |
|  | <b>300</b>   | SSG16C30   | SSG16C30Y  | TG16C30  | SSG25C30   | SSG25C30Y  | TG25C30  | SSG35C30   | SSG35C30Y |
|  | <b>400</b>   | SSG16C40   | SSG16C40Y  | TG16C40  | SSG25C40   | SSG25C40Y  | TG25C40  | SSG35C40   | SSG35C40Y |
|  | <b>500</b>   | SSG16C50   | SSG16C50Y  | TG16C50  | SSG25C50   | SSG25C50Y  | TG25C50  | SSG35C50   | SSG35C50Y |
|  | <b>600</b>   | SSG16C60   | SSG16C60Y  | TG16C60  | SSG25C60   | SSG25C60Y  | TG25C60  | SSG35C60   | SSG35C60Y |
|  | <b>800</b>   | SSG16C80   | SSG16C80Y  |  | SSG25C80   | SSG25C80Y  |  | SSG35C80   |           |
|  | <b>1,000</b>   | SSG16C100  | SSG16C100Y   |  | SSG25C100  | SSG25C100Y   |  | SSG35C100  |           |
| <b>1,200</b>                           | SSG16C120  | SSG16C120Y   |  | SSG25C120  | SSG25C120Y   |  | SSG35C120  |  |           |
| $I_{TSM}$ [A]                          | 140/160  | 140/160  | 140/160  | 220/250  | 220/250  | 220/250  | 350/400  | 300/330  |           |
| $I^2t$ [ $\text{A}^2\cdot\text{sec}$ ] | 106  | 106  | 106  | 260  | 260  | 260  | 660  | 450  |           |
| $di/dt$ [ $\text{A}/\mu\text{s}$ ]     | 50   | 50   | 50   | 50   | 50   | 50   | 50   | 50   |           |
| $I_{DRM}$ [mA]                         | 3  | 3  | 3  | 5  | 5  | 5  | 6  | 5  |           |
| $V_{TM}$ [V]                           | 1.7  | 1.7  | 1.5  | 1.6  | 1.6  | 1.4  | 1.6  | 1.4  |           |
| $I_{GT}$ [mA]                          | 50   | 50   | 50   | 70   | 70   | 50   | 70   | 50   |           |
| $V_{GT}$ [V]                           | 3  | 3  | 3  | 3  | 3  | 3  | 3  | 3  |           |
| $V_{GD}$ [V]                           | 0.2  | 0.2  | 0.2  | 0.2  | 0.2  | 0.2  | 0.2  | 0.2  |           |
| $(dv/dt)_c$ [ $\text{V}/\mu\text{s}$ ] | 6  | 6  | 6  | 20   | 20   | 6  | 20   | 5  |           |
| $T_j$ [ $^\circ\text{C}$ ]             | -30~+125   | -25~+125   | -25~+125   | -30~+125   | -25~+125   | -25~+125   | -30~+125   | -25~+125   |           |
| $R_{th}$ [ $^\circ\text{C}/\text{W}$ ] | 1.2  | 1.8  | 2.0  | 1.0  | 1.4  | 1.6  | 0.8  | 1.4  |           |
| $V_{ISO}$ [V]                          |  | 2,500  | 2,500  |  | 2,500  | 2,500  |  | 2,500  |           |
| Package<br>Outline                     | S1, D1   | Y1   | T1   | S2   | Y2   | T1   | S3   | Y2   |           |

# SanRex TRIACS

| $I_{T(RMS)}$ [A]                       | <b>45<sub>amp</sub></b><br>( $T_c=82^\circ\text{C}$ )<br>Harmetic Stud | <b>50<sub>amp</sub></b><br>( $T_c=85^\circ\text{C}$ )<br>Harmetic Stud | <b>70<sub>amp</sub></b><br>( $T_c=85^\circ\text{C}$ )<br>Harmetic Stud | <b>70<sub>amp</sub></b><br>( $T_c=85^\circ\text{C}$ )<br>Low Cost Harmetic Stud | <b>100<sub>amp</sub></b><br>( $T_c=83^\circ\text{C}$ )<br>Harmetic Stud | <b>150<sub>amp</sub></b><br>( $T_c=84^\circ\text{C}$ )<br>Harmetic Stud | <b>300<sub>amp</sub></b><br>( $T_c=89^\circ\text{C}$ )<br>Harmetic Stud |            |
|--|--|--|--|---|---|---|---|------------|
| $V_{DRM}$ [V]                          | 200  | SSG45C20   | SSG50C20   | SSG70C20  | SSG70D20  | SSG100C20   | SSG150C20   | SSG300C20  |
|  | 300  | SSG45C30   | SSG50C30   | SSG70C30  | SSG70D30  | SSG100C30   | SSG150C30   | SSG300C30  |
|  | 400  | SSG45C40   | SSG50C40   | SSG70C40  | SSG70D40  | SSG100C40   | SSG150C40   | SSG300C40  |
|  | 500  | SSG45C50   | SSG50C50   | SSG70C50  | SSG70D50  | SSG100C50   | SSG150C50   | SSG300C50  |
|  | 600  | SSG45C60   | SSG50C60   | SSG70C60  | SSG70D60  | SSG100C60   | SSG150C60   | SSG300C60  |
|  | 800  | SSG45C80   | SSG50C80   | SSG70C80  |   | SSG100C80   | SSG150C80   | SSG300C80  |
|  | 1,000  | SSG45C100  | SSG50C100  | SSG70C100   |   | SSG100C100  | SSG150C100  | SSG300C100 |
|  | 1,200  | SSG45C120  | SSG50C120  | SSG70C120   |   | SSG100C120  | SSG150C120  | SSG300C120 |
| $I_{TSM}$ [A]                          | 500/550  | 720/800  | 900/1,000  | 900/1,000   | 1,080/1,200   | 1,980/2,200   | 3,000/3,300   |            |
| $I^2t$ [ $\text{A}^2\cdot\text{sec}$ ] | 1,260  | 2,660  | 4,100  | 4,100   | 6,000   | 20,000  | 45,000  |            |
| $di/dt$ [ $\text{A}/\mu\text{s}$ ]     | 50   | 50   | 50   | 50  | 50  | 50  | 50  |            |
| $I_{DRM}$ [mA]                         | 6  | 8  | 10   | 10  | 10  | 15  | 25  |            |
| $V_{TM}$ [V]                           | 1.6  | 1.5  | 1.5  | 1.5   | 1.55  | 1.5   | 1.5   |            |
| $I_{GT}$ [mA]                          | 70   | 150  | 200  | 200   | 200   | 400   | 400   |            |
| $V_{GT}$ [V]                           | 3  | 3  | 3  | 3   | 3   | 3   | 3   |            |
| $V_{GD}$ [V]                           | 0.2  | 0.2  | 0.2  | 0.2   | 0.2   | 0.2   | 0.25  |            |
| $(dv/dt)_c$ [ $\text{V}/\mu\text{s}$ ] | 20   | 20   | 20   | 20  | 20  | 50  | 100   |            |
| $T_j$ [ $^\circ\text{C}$ ]             | -30~+125   | -30~+125   | -30~+125   | -30~+125  | -30~+125  | -30~+125  | -30~+125  |            |
| $R_{th}$ [ $^\circ\text{C}/\text{W}$ ] | 0.65   | 0.6  | 0.4  | 0.4   | 0.3   | 0.2   | 0.09  |            |
| Package Outline                        | S3   | S4   | S5   | S6  | S5  | S7  | S8  |            |

$I_{T(RMS)}$  RMS On-State Current  
 $V_{DRM}$  Repetitive Peak Off-State Voltage  
 $I_{TSM}$  Surge On-State Current  
 $I^2t$   $I^2t$  for fusing (2~10msec)  
 $di/dt$  Critical Rate of Rise of On-State Current  
 ( $I_c = \frac{1}{3}I_{GT}$ ,  $T_j = 25^\circ\text{C}$ ,  
 $V_D = \frac{1}{2}V_{DRM}$ ,  $di_G/dt = 1\text{A}/\mu\text{s}$ )

$I_{DRM}$  Peak Off-State Current, max.(at  $V_{DRM}$  Single phase half wave)  
 $V_{TM}$  Peak On-State Voltage, max.( $I_T \div 1.4I_{T(RMS)}$ ,  $T_j = 25^\circ\text{C}$ )  
 $I_{GT}$  Gate Trigger Current, max.( $T_j = 25^\circ\text{C}$ ,  $I_T = 1\text{A}$ ,  $V_D = 6\text{V}$ )  
 $V_{GT}$  Gate Trigger Voltage, max.( $T_j = 25^\circ\text{C}$ ,  $I_T = 1\text{A}$ ,  $V_D = 6\text{V}$ )  
 $V_{GD}$  Non-Trigger Gate Voltage, min.( $T_j = 125^\circ\text{C}$ ,  $V_D = \frac{1}{2}V_{DRM}$ )  
 $(dv/dt)_c$  Critical Rate of Rise of Off-State Voltage at Commutation, min.  
 ( $T_j = 125^\circ\text{C}$ ,  $V_D = \frac{2}{3}V_{DRM}$ ,  $|di/dt|_c = \frac{1}{2}I_{T(RMS)}\text{A}/\mu\text{s}$ )  
 $R_{th}$  Thermal Impedance, max.  
 $T_j$  Operating Junction Temperature Range  
 $V_{ISO}$  Isolation Breakdown Voltage (RMS, 1min.)

**SanRex SCRs**

| $I_{T(AV)}$ [A]                                |                                       | <b>10<sub>amp</sub></b><br>( $T_c=104^\circ\text{C}$ )<br>Harmetic | <b>16<sub>amp</sub></b><br>( $T_c=88^\circ\text{C}$ )<br>Harmetic Stud | <b>20<sub>amp</sub></b><br>( $T_c=88^\circ\text{C}$ )<br>Harmetic Stud | <b>30<sub>amp</sub></b><br>( $T_c=81^\circ\text{C}$ )<br>Harmetic Stud | <b>40<sub>amp</sub></b><br>( $T_c=81^\circ\text{C}$ )<br>Harmetic Stud | <b>70<sub>amp</sub></b><br>( $T_c=83^\circ\text{C}$ )<br>Harmetic Stud | <b>100<sub>amp</sub></b><br>( $T_c=93^\circ\text{C}$ )<br>Harmetic Stud |
|--|---------------------------------------|--|--|--|--|--|--|---|
| $V_{RRM}$<br>$V_{DRM}$<br>( $V_{RSM}$ )<br>[V] | <b>200</b><br>(240)                   | SC10C20  | SC16C20  | SC20C20  | SC30C20  | SC40C20  | SC70C20  | SC100C20  |
|  | <b>300</b><br>(360)                   | SC10C30  | SC16C30  | SC20C30  | SC30C30  | SC40C30  | SC70C30  | SC100C30  |
|  | <b>400</b><br>(480)                   | SC10C40  | SC16C40  | SC20C40  | SC30C40  | SC40C40  | SC70C40  | SC100C40  |
|  | <b>500</b><br>(600)                   | SC10C50  | SC16C50  | SC20C50  | SC30C50  | SC40C50  | SC70C50  | SC100C50  |
|  | <b>600</b><br>(720)                   | SC10C60  | SC16C60  | SC20C60  | SC30C60  | SC40C60  | SC70C60  | SC100C60  |
|  | <b>800</b><br>(960)                   | SC10C80  | SC16C80  | SC20C80  | SC30C80  | SC40C80  | SC70C80  | SC100C80  |
|  | <b>1,000</b><br>(1,100)               | SC10C100   | SC16C100   | SC20C100   | SC30C100   | SC40C100   | SC70C100   | SC100C100   |
| <b>1,200</b><br>(1,300)                        | SC10C120                              | SC16C120   | SC20C120   | SC30C120   | SC40C120   | SC70C120   | SC100C120  |   |
| $I_{T(RMS)}$ [A]                               | 15                                    | 25   | 30   | 47   | 62   | 110  | 160  |   |
| $I_{TSM}$<br>(50/60Hz) [A]                     | 180/200                               | 220/250  | 360/400  | 540/600  | 900/1,000  | 1,800/2,000  | 2,000/2,200  |   |
| $I^2t$ [ $\text{A}^2 \cdot \text{sec}$ ]       | 165                                   | 260  | 660  | 1,500  | 4,160  | 16,600   | 20,100   |   |
| $di/dt$ [ $\text{A}/\mu\text{s}$ ]             | 100                                   | 100  | 100  | 100  | 50 ( $V_{DRM}=200\sim 600\text{V}$ )                                   |  | 200 ( $V_{DRM}=$   |   |
| $I_{DRM}, I_{RRM}$ [mA]                        | 3                                     | 3  | 5  | 5  | 5  | 10   | 15   |   |
| $V_{TM}$ [V]                                   | 1.7                                   | 1.9  | 1.8  | 1.8  | 1.8  | 1.5  | 1.6  |   |
| $I_{GT}$ [mA]                                  | 40                                    | 40   | 50   | 50   | 70   | 70   | 100  |   |
| $V_{GT}$ [V]                                   | 3                                     | 3  | 3  | 3  | 3  | 3  | 3  |   |
| $V_{GD}$ [V]                                   | 0.2                                   | 0.2  | 0.25   | 0.25   | 0.25   | 0.25   | 0.25   |   |
| $dv/dt$ [ $\text{V}/\mu\text{s}$ ]             | 100 ( $V_{DRM}=200\sim 600\text{V}$ ) |  |  |  |  |  |  | 200 ( $V_{DRM}=800\sim 1200\text{V}$ )                                  |
| $T_j$ [ $^\circ\text{C}$ ]                     | -30~+125                              | -30~+125   | -30~+125   | -30~+125   | -30~+125   | -30~+125   | -30~+125   |   |
| $R_{th}$ [ $^\circ\text{C}/\text{W}$ ]         | 1.2                                   | 1.2  | 1.0  | 0.8  | 0.6  | 0.4  | 0.2  |   |
| Package Outline                                | S1, D1                                | S2   | S3   | S3   | S4   | S5   | S7   |   |

# SanRex SCRs for welders

| 150 <sub>amp</sub><br>(T <sub>c</sub> =84°C)<br>Harmetic Stud |             | 300 <sub>amp</sub><br>(T <sub>c</sub> =85°C)<br>Harmetic Stud      |              | I <sub>T(AV)</sub> [A]                   | 60 <sub>amp</sub><br>(T <sub>c</sub> =115°C)<br>Harmetic Stud | 80 <sub>amp</sub><br>(T <sub>c</sub> =107°C)<br>Harmetic Stud | 100 <sub>amp</sub><br>(T <sub>c</sub> =105°C)<br>Harmetic Stud | 120 <sub>amp</sub><br>(T <sub>c</sub> =115°C)<br>Harmetic Stud | 250 <sub>amp</sub><br>(T <sub>c</sub> =97°C)<br>Harmetic Stud |
|---|-------------|--|--------------|--|---|---|--|--|---|
| SC150C20  | SC300C20    | V <sub>RRM</sub><br>V <sub>DRM</sub><br>(V <sub>RSM</sub> )<br>[V] | 200<br>(240) | AS60C20                                  | AS80C20   | AS100C20  | AS120C20   | AS250C20   |   |
| SC150C30  | SC300C30    |  | 300<br>(360) | AS60C30                                  | AS80C30   | AS100C30  | AS120C30   | AS250C30   |   |
| SC150C40  | SC300C40    |  | 400<br>(480) | AS60C40                                  | AS80C40   | AS100C40  | AS120C40   | AS250C40   |   |
| SC150C50  | SC300C50    |  |              |  |   |   |  |  |   |
| SC150C60  | SC300C60    |  |              | I <sub>T(RMS)</sub> [A]                  | 94  | 125   | 157  | 188  | 390   |
| SC150C80  | SC300C80    |  |              | I <sub>TSM</sub><br>(50/60Hz) [A]        | 1,800/2,000   | 2,250/2,500   | 2,700/3,000  | 3,600/4,000  | 5,000/5,500   |
| SC150C100   | SC300C100   |  |              | I <sup>2</sup> t [A <sup>2</sup> ·sec]   | 16,700  | 26,000  | 37,500   | 66,000   | 126,000   |
| SC150C120   | SC300C120   |  |              | di/dt [A/μs]                             | 50  | 50  | 50   | 50   | 50  |
| 230   | 470         |  |              | I <sub>DRM</sub> , I <sub>RRM</sub> [mA] | 10  | 10  | 15   | 15   | 25  |
| 2,700/3,000   | 6,300/7,000 |  |              | V <sub>TM</sub> [V]                      | 1.47  | 1.34  | 1.30   | 1.22   | 1.40  |
| 37,500  | 204,000     |  |              | I <sub>GT</sub> [mA]                     | 70  | 70  | 70   | 70   | 100   |
| 800~1,200V)   |             |  |              | V <sub>GT</sub> [V]                      | 2   | 2   | 2  | 2  | 3   |
| 15  | 25          |  |              | V <sub>GD</sub> [V]                      | 0.25  | 0.25  | 0.25   | 0.25   | 0.25  |
| 1.6   | 1.45        |  |              | dv/dt [V/μs]                             | 5   | 5   | 5  | 5  | 5   |
| 100   | 100         |  |              | T <sub>j</sub> [°C]                      | -30~+150  | -30~+150  | -30~+150   | -30~+150   | -30~+150  |
| 3   | 3           |  |              | R <sub>th</sub> [°C/W]                   | 0.4   | 0.4   | 0.35   | 0.24   | 0.15  |
| 0.25  | 0.25        |  |              | Package Outline                          | S6.1  | S6.1  | S11  | S11  | S9  |
| -30~+125  | -30~+125    |  |              |  |   |   |  |  |   |
| 0.17  | 0.09        |  |              |  |   |   |  |  |   |
| S9  | S8          |  |              |  |   |   |  |  |   |

I<sub>T(AV)</sub> Average On-State Current  
 V<sub>RRM</sub> Repetitive Peak Reverse Voltage  
 V<sub>DRM</sub> Repetitive Peak Off-State Voltage  
 V<sub>RSM</sub> Non-Repetitive Peak Reverse Voltage  
 I<sub>T(RMS)</sub> RMS On-State Current  
 I<sub>TSM</sub> Surge On-State Current  
 I<sup>2</sup>t I<sup>2</sup>t for fusing (2~10msec)  
 di/dt Critical Rate of Rise of On-State Current  
 (I<sub>G</sub> ≐ 1/3 I<sub>GT</sub>, T<sub>j</sub>=25°C, V<sub>D</sub>=1/2 V<sub>DRM</sub>, di/dt=1A/μs)  
 I<sub>DRM</sub> Repetitive Peak Off-State Current, max.  
 (at V<sub>DRM</sub>, Single phase half wave)  
 I<sub>RRM</sub> Repetitive Peak Reverse Current, max.  
 (at V<sub>RRM</sub>, Single phase half wave)

V<sub>TM</sub> Peak On-State Voltage, max.  
 (I<sub>T</sub> ≐ 1.4 I<sub>T(RMS)</sub>, T<sub>j</sub>=25°C)  
 I<sub>GT</sub> Gate Trigger Current, max.  
 (T<sub>j</sub>=25°C, I<sub>T</sub>=1A, V<sub>D</sub>=6V)  
 V<sub>GT</sub> Gate Trigger Voltage, max.  
 (T<sub>j</sub>=25°C, I<sub>T</sub>=1A, V<sub>D</sub>=6V)  
 V<sub>GD</sub> Non-Trigger Gate Voltage, min.  
 (T<sub>j</sub>=125°C, V<sub>D</sub>=1/2 V<sub>DRM</sub>)  
 dv/dt Critical Rate of Rise of Off-State Voltage, min.  
 (T<sub>j</sub>=125°C, V<sub>D</sub>=2/3 V<sub>DRM</sub> Exponential wave)  
 T<sub>j</sub> Operating Junction Temperature Range  
 R<sub>th</sub> Thermal Impedance, max.

# SanRex THYRISTOR MODULES

| $I_{T(AV)}$ [V]    |                               | 25 <sub>amp</sub><br>( $T_c=93^\circ\text{C}$ ) | 25 <sub>amp</sub><br>( $T_c=93^\circ\text{C}$ ) | 40 <sub>amp</sub><br>( $T_c=83^\circ\text{C}$ ) | 40 <sub>amp</sub><br>( $T_c=83^\circ\text{C}$ ) | 50 <sub>amp</sub><br>( $T_c=81^\circ\text{C}$ ) | 50 <sub>amp</sub><br>( $T_c=81^\circ\text{C}$ ) | 70 <sub>amp</sub><br>( $T_c=81^\circ\text{C}$ ) | 70 <sub>amp</sub><br>( $T_c=81^\circ\text{C}$ ) |
|--------------------|-------------------------------|---|---|---|---|---|---|---|---|
|                    |                               |   |   |   |   |   |   |   |   |
| $V_{RRM}$          | 200<br>(240)                  | PK25C20   | PD25C20   | PK40C20   | PD40C20   | PK50C20   | PD50C20   | PK70C20   | PD70C20   |
| $V_{DRM}$          | 400<br>(480)                  | PK25C40   | PD25C40   | PK40C40   | PD40C40   | PK50C40   | PD50C40   | PK70C40   | PD70C40   |
| $V_{RSM}$          | 600<br>(720)                  | PK25C60   | PD25C60   | PK40C60   | PD40C60   | PK50C60   | PD50C60   | PK70C60   | PD70C60   |
| [V]                | 800<br>(960)                  | PK25C80   | PD25C80   | PK40C80   | PD40C80   | PK50C80   | PD50C80   | PK70C80   | PD70C80   |
| $I_{T(RMS)}$       | [A]                           | 39  |   | 62  |   | 78  |   | 110   |   |
| $I_{TSM}$          | [A]                           | 450/500   |   | 720/800   |   | 900/1,000                                       |   | 1,250/1,400                                     |   |
| $I^2t$             | [A <sup>2</sup> ·sec]         | 1,000   |   | 2,700   |   | 4,150   |   | 8,100   |   |
| $di/dt$            | [A/ $\mu\text{s}$ ]           | 100   |   | 150   |   | 150   |   | 150   |   |
| $I_{DRM}, I_{RRM}$ | [mA]                          | 5   |   | 8   |   | 10  |   | 12  |   |
| $V_{TM}$           | [V]                           | 1.55  |   | 1.50  |   | 1.45  |   | 1.40  |   |
| $I_{GT}$           | [mA]                          | 50  |   | 70  |   | 70  |   | 70  |   |
| $V_{GT}$           | [V]                           | 3   |   | 3   |   | 3   |   | 3   |   |
| $V_{GD}$           | [V]                           | 0.25  |   | 0.25  |   | 0.25  |   | 0.25  |   |
| $dv/dt$            | [V/ $\mu\text{s}$ ]           | 500   |   | 500   |   | 500   |   | 500   |   |
| $T_j$              | [ $^\circ\text{C}$ ]          | -30~+125  |   | -30~+125  |   | -30~+125  |   | -30~+125  |   |
| $R_{th}$           | [ $^\circ\text{C}/\text{W}$ ] | 0.8   |   | 0.7   |   | 0.6   |   | 0.45  |   |
| $V_{iso}$          | [V]                           | 2,500   |   | 2,500   |   | 2,500   |   | 2,500   |   |
| $R_{iso}$          | [M $\Omega$ ]                 | 1,000   |   | 1,000   |   | 1,000   |   | 1,000   |   |
| Package Outline    |                               | M1  |   | M1  |   | M1  |   | M1  |   |

$I_{T(AV)}$  Average On-State Current  
 $V_{RRM}$  Repetitive Peak Reverse Voltage  
 $V_{DRM}$  Repetitive Peak Off-State Voltage  
 $V_{RSM}$  Non-Repetitive Peak Reverse Voltage  
 $I_{T(RMS)}$  RMS On-State Current  
 $I_{TSM}$  Surge On-State Current  
 $I^2t$   $I^2t$  for fusing (2~10msec)  
 $di/dt$  Critical Rate of Rise of On-State Current  
 $(I_G \div \frac{1}{3} I_{GT}, T_j=25^\circ\text{C}, V_D = \frac{1}{2} V_{DRM}, di/dt=1\text{A}/\mu\text{s})$   
 $I_{DRM}$  Repetitive Peak Off-State Current, max.  
 (at  $V_{DRM}$  Single phase half wave)  
 $I_{RRM}$  Repetitive Peak Reverse Current, max.  
 (at  $V_{RRM}$  Single phase half wave)

$V_{TM}$  Peak On-State Voltage, max. ( $I_T \div 1.4 I_{T(RMS)}, T_j=25^\circ\text{C}$ )  
 $I_{GT}$  Gate Trigger Current, max. ( $T_j=25^\circ\text{C}, I_T=1\text{A}, V_D=6\text{V}$ )  
 $V_{GT}$  Gate Trigger Voltage, max. ( $T_j=25^\circ\text{C}, I_T=1\text{A}, V_D=6\text{V}$ )  
 $V_{GD}$  Non-Trigger Gate Voltage, min. ( $T_j=125^\circ\text{C}, V_D = \frac{1}{2} V_{DRM}$ )  
 $dv/dt$  Critical Rate of Rise of Off-State Voltage, min.  
 $(T_j=125^\circ\text{C}, V_D = \frac{2}{3} V_{DRM}, \text{Exponential wave})$   
 $T_j$  Operating Junction Temperature Range  
 $R_{th}$  Thermal Impedance, max.  
 $V_{iso}$  Isolation Breakdown Voltage (RMS, 1min)  
 $R_{iso}$  Isolation Resistance (D.C. 1,000V 5sec)

# Fast Switching Power TRANSISTORS

| 100 <sub>amp</sub><br>(T <sub>c</sub> =83°C) |          | 100 <sub>amp</sub><br>(T <sub>c</sub> =83°C) |  | I <sub>c</sub> [A]   | 25 <sub>amp</sub><br>Harmetic<br>Diamond Base |          |  | 50 <sub>amp</sub><br>Harmetic<br>Stud |          |          |
|--|----------|--|--|--|---|----------|--|---------------------------------------|----------|----------|
|  |          |  |  |  | SQ25FE40                                      | SQ25FE60 | SQ25FE80   | SQ50FE40                              | SQ50FE60 | SQ50FE80 |
| PK100C20                                     | PD100C20 | V <sub>CBO</sub> [V]                         |  | 500  | 700   | 900      | 500  | 700                                   | 900      |          |
| PK100C40                                     | PD100C40 | V <sub>CEO</sub> [V]                         |  | 250  | 450   | 450      | 250  | 450                                   | 450      |          |
| PK100C60                                     | PD100C60 | V <sub>CEX(SUS)</sub> [V]                    |  | 400  | 600   | 800      | 400  | 600                                   | 800      |          |
| PK100C80                                     | PD100C80 | V <sub>CER(SUS)</sub> [V]                    |  | 300  | 500   | 500      | 300  | 500                                   | 500      |          |
| 160  |          | V <sub>EBO</sub> [V]                         |  | 10   |   |          | 10   |                                       |          |          |
| 1,800/2,000                                  |          | I <sub>c pulse</sub> [A]                     |  | 50   |   |          | 100  |                                       |          |          |
| 16,600                                       |          | I <sub>B</sub> [A]                           |  | 10 (I <sub>B pulse</sub> 20)   |   |          | 15 (I <sub>B pulse</sub> 30)   |                                       |          |          |
| 200  |          | P <sub>T</sub> [W]                           |  | 200  |   |          | 350  |                                       |          |          |
| 15   |          | I <sub>CBO</sub> [mA]                        |  | 1.0  |   |          | 1.0  |                                       |          |          |
| 1.40   |          | I <sub>EBO</sub> [mA]                        |  | 1.0  |   |          | 1.0  |                                       |          |          |
| 100  |          | h <sub>FE</sub>                              |  | 8 (I <sub>c</sub> =15A, V <sub>CE</sub> =2V)<br>7.5 (I <sub>c</sub> =25A, V <sub>CE</sub> =5V) |   |          | 9 (I <sub>c</sub> =30A, V <sub>CE</sub> =2V)<br>9 (I <sub>c</sub> =50A, V <sub>CE</sub> =5V) |                                       |          |          |
| 3  |          | V <sub>CE(Sat)</sub> [V]                     |  | 1.2  |   |          | 1.0  |                                       |          |          |
| 0.25   |          | V <sub>BE(Sat)</sub> [V]                     |  | 1.8  |   |          | 1.8  |                                       |          |          |
| 500  |          | t <sub>on</sub> [μs]                         |  | 2.0  |   |          | 2.0  |                                       |          |          |
| -30~+125                                     |          | t <sub>s</sub> [μs]                          |  | 3.0  |   |          | 3.5  |                                       |          |          |
| 0.3  |          | t <sub>f</sub> [μs]                          |  | 0.5  |   |          | 0.5  |                                       |          |          |
| 2,500  |          | T <sub>j</sub> , T <sub>stg</sub> [°C]       |  | -30~+150   |   |          | -30~+150   |                                       |          |          |
| 1,000  |          | R <sub>th</sub> [°C/W]                       |  | 0.63   |   |          | 0.36   |                                       |          |          |
| M1   |          | Package Outline                              |  | D2   |   |          | S4.1   |                                       |          |          |

- I<sub>c</sub> Collector Current
- V<sub>CBO</sub> Collector-Base Voltage
- V<sub>CEO</sub> Collector-Emitter Voltage
- V<sub>CEX(SUS)</sub> Collector-Emitter Sustaining Voltage (I<sub>c</sub>=1A, V<sub>EB</sub>=8V)
- V<sub>CER(SUS)</sub> Collector-Emitter Sustaining Voltage (I<sub>c</sub>=1A, R<sub>BE</sub>=50Ω)
- V<sub>EBO</sub> Emitter-Base Voltage
- I<sub>c pulse</sub> Collector Pulse Current
- I<sub>B</sub> Base Current
- P<sub>T</sub> Total Power Dissipation
- I<sub>CBO</sub> Collector Cutoff Current
- I<sub>EBO</sub> Emitter Cutoff Current
- h<sub>FE</sub> DC Current Gain
- V<sub>CE(Sat)</sub> Collector-Emitter Saturation Voltage (I<sub>c</sub>=Rating, I<sub>B</sub>=1/5 I<sub>c</sub>)
- V<sub>BE(Sat)</sub> Base-Emitter Saturation Voltage (I<sub>c</sub>=Rating, I<sub>B</sub>=1/5 I<sub>c</sub>)
- t<sub>on</sub> On Time
- t<sub>s</sub> Storage Time

- t<sub>f</sub> Fall Time
- T<sub>j</sub>, T<sub>stg</sub> Operating Junction, Storage Temperature
- R<sub>th</sub> Thermal Impedance

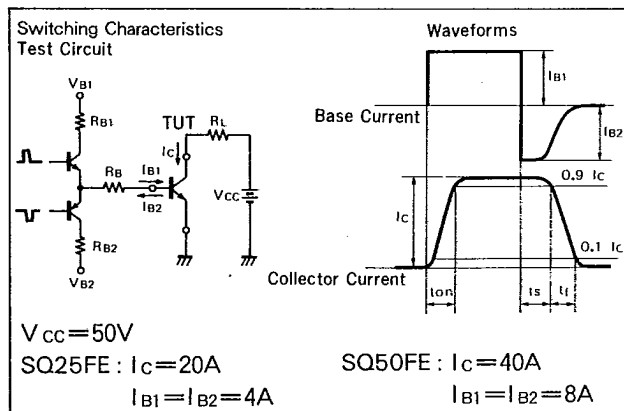

# SanRex Fast Switching Thyristors

| $I_{T(AV)}$ [A]                                      |              | 16amp<br>( $T_c=77^\circ\text{C}$ )<br>Fast Switching SCR<br>$t_q \leq 10\mu\text{s}$ | 20amp<br>( $T_c=75^\circ\text{C}$ )<br>Fast Switching SCR<br>$t_q \leq 10\mu\text{s}$ | 30amp<br>( $T_c=65^\circ\text{C}$ )<br>Fast Switching SCR<br>$t_q \leq 10\mu\text{s}$ | 70amp<br>( $T_c=74^\circ\text{C}$ )<br>Fast Switching SCR<br>$t_q \leq 30\mu\text{s}$ | 150amp<br>( $T_c=79^\circ\text{C}$ )<br>Fast Switching SCR<br>$t_q \leq 10\mu\text{s}$ | 30amp<br>( $T_c=85^\circ\text{C}$ )<br>High Freq<br>Switching SCR<br>$t_q \leq 7.5\mu\text{s}$ | 20amp<br>( $T_c=90^\circ\text{C}$ )<br>Reverse<br>Conductive<br>Thyristor |
|--|--------------|---|---|---|---|--|--|---|
| $V_{RRM}^*$<br>$V_{DRM}$<br>( $V_{RSM}^*$ )**<br>[V] | 100<br>(120) | SC16C10J  | SC20C10J  | SC30C10J  | SC70C10L  | SC150C10J  |  |   |
|  | 200<br>(240) | SC16C20J  | SC20C20J  | SC30C20J  | SC70C20L  | SC150C20J  |  |   |
|  | 300<br>(360) | SC16C30J  | SC20C30J  | SC30C30J  | SC70C30L  | SC150C30J  |  |   |
|  | 400<br>(480) | SC16C40J  | SC20C40J  | SC30C40J  | SC70C40L  | SC150C40J  | SC20C40H   | SN20C40   |
|  | 500<br>(600) | SC16C50J  | SC20C50J  | SC30C50J  | SC70C50L  | SC150C50J  | SC20C50H   | SN20C50   |
|  | 600<br>(720) | SC16C60J  | SC20C60J  | SC30C60J  | SC70C60L  |  | SC20C60H   | SN20C60   |
|  | 700          |   |   |   |   |  | SC20C70H   | SN20C70   |
|  | 800          |   |   |   |   |  |  | SN20C80   |
|  | 900          |   |   |   |   |  |  | SN20C90   |
| $I_{T(RMS)}$ [A]                                     | 25           | 30  | 47  | 110   | 230   | 47   | 30( $V_{R(RMS)}=10$ )  |   |
| $I_{TSM}$<br>(50/60Hz) [A]                           | 220/250      | 300/340   | 450/500   | 1,350/1,500   | 4,000/4,400   | 450/500  | 260/300  |   |
| $I^2t$ [ $A^2 \cdot \text{sec}$ ]                    | 260          | 480   | 1,040   | 9,370   | 80,600  | 1,040  | 370  |   |
| $di/dt$ [ $A/\mu\text{s}$ ]                          | 50           | 50  | 50  | 50  | 200   | 200  | 28 ( $f \leq 28\text{kHz}$ )   |   |
| $I_{DRM}, I_{RRM}$ [mA]                              | 6            | 10  | 10  | 10  | 15  | 10   | 5  |   |
| $V_{TM}$ [V]   | 2.5          | 2.5   | 2.5   | 1.8   | 1.8   | 2.5  | 2.2  |   |
| $I_{GT}$ [mA]  | 50           | 70  | 70  | 70  | 100   | 150  | 120  |   |
| $V_{GT}$ [V]   | 3            | 3   | 3   | 3   | 3   | 1.55   | 1.1  |   |
| $V_{GD}$ [V]   | 0.25         | 0.25  | 0.25  | 0.25  | 0.25  | 0.25   | 0.25   |   |
| $t_q$ [ $\mu\text{s}$ ]                              | 10           | 10  | 10  | 30  | 10  | 7.5  | 12   |   |
| $dv/dt$ [ $V/\mu\text{s}$ ]                          | 100          | 100   | 100   | 100   | 200   | 1,100  | 1,000  |   |
| $T_j$ [ $^\circ\text{C}$ ]                           | -30~+125     | -30~+125  | -30~+125  | -30~+125  | -30~+125  | -30~+125   | -30~+125   |   |
| $R_{th}$ [ $^\circ\text{C}/\text{W}$ ]               | 1.2          | 1.0   | 0.8   | 0.4   | 0.17  | 0.55   | 0.58   |   |
| Package<br>Outline                                   | S2           | S3  | S3  | S5  | S9  | S2   | S2.1   |   |

\*Not Applicable for SN20C

\*\*Not Applicable for SC20C-H or SN20C

|              |   |          |   |
|--------------|---|----------|---|
| $I_{T(AV)}$  | Average On-State Current  | $V_{TM}$ | Peak On-State Voltage, max. ( $I_T = 1.4 I_{T(RMS)}, T_j = 25^\circ\text{C}$ )  |
| $V_{RRM}$    | Repetitive Peak Reverse Voltage   | $I_{GT}$ | Gate Trigger Current, max. ( $T_j = 25^\circ\text{C}, I_T = 1\text{A}, V_D = 6\text{V}$ )   |
| $V_{DRM}$    | Repetitive Peak Off-State Voltage   | $V_{GT}$ | Gate Trigger Voltage, max. ( $T_j = 25^\circ\text{C}, I_T = 1\text{A}, V_D = 6\text{V}$ )   |
| $V_{RSM}$    | Non-Repetitive Peak Reverse Voltage   | $V_{GD}$ | Non-Trigger Gate Voltage, min. ( $T_j = 125^\circ\text{C}, V_D = \frac{1}{2} V_{DRM}$ )   |
| $I_{T(RMS)}$ | RMS On-State Current  | $t_q$    | Turn Off Time, max. ( $T_j = 125^\circ\text{C}, I_T = I_{T(AV)}, V_R = 50\text{V}, V_D = \frac{1}{2} V_{DRM}, dv/dt = 20\text{V}/\mu\text{s}$ ) |
| $I_{TSM}$    | Surge On-State Current  | $dv/dt$  | Critical Rate of Rise of Off-State Voltage, min. ( $T_j = 125^\circ\text{C}, V_D = \frac{2}{3} V_{DRM}, \text{Exponential wave}$ )              |
| $I^2t$       | $I^2t$ for fusing (2~10msec)  | $T_j$    | Operating Junction Temperature Range  |
| $di/dt$      | Critical Rate of Rise of On-State Current<br>( $I_G = \frac{1}{3} I_{GT}, T_j = 25^\circ\text{C}, V_D = \frac{1}{2} V_{DRM}, di_G/dt = 1\text{A}/\mu\text{s}$ ) | $R_{th}$ | Thermal Impedance, max.   |
| $I_{DRM}$    | Repetitive Peak Off-State Current, max.<br>(at $V_{DRM}$ , Single phase half wave)  |          |   |
| $I_{RRM}$    | Repetitive Peak Reverse Current, max.<br>(at $V_{RRM}$ , Single phase half wave)  |          |   |

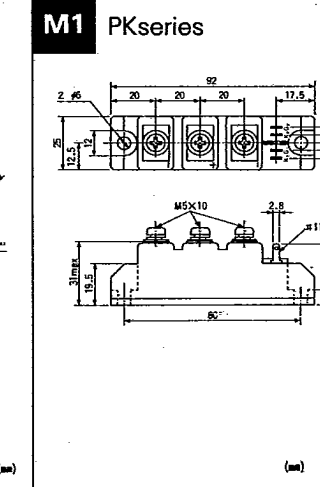
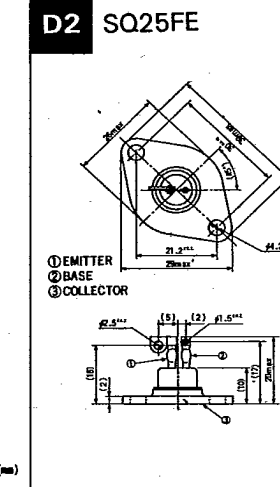
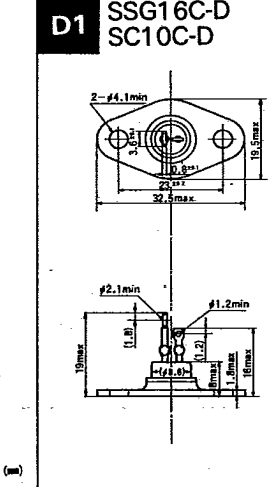
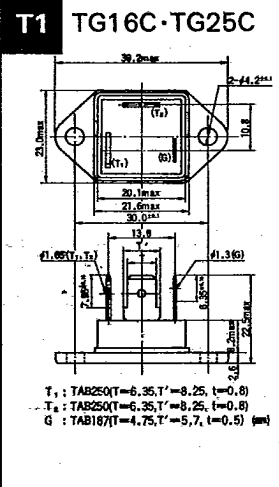
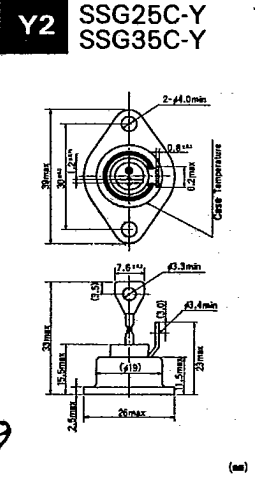
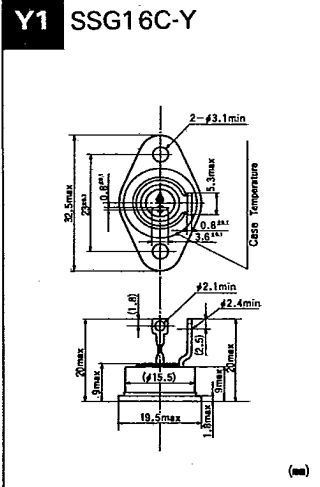
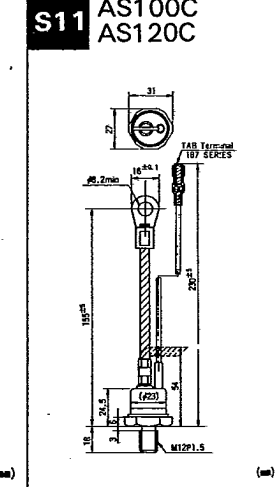
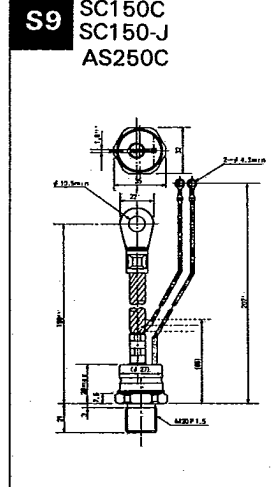
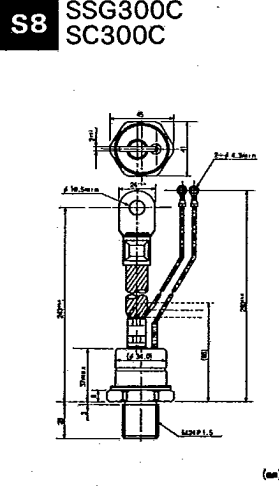
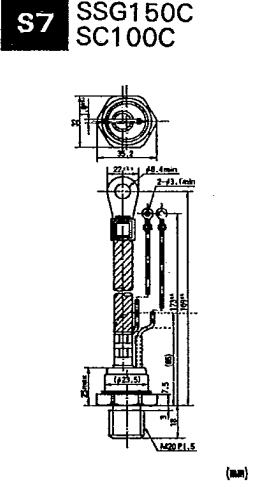
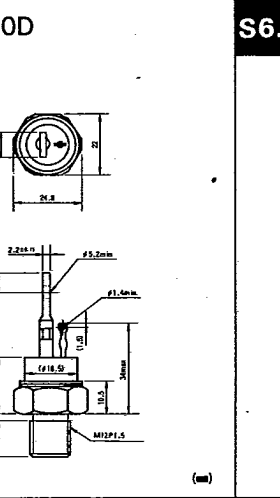
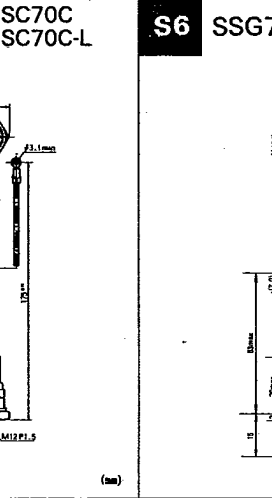
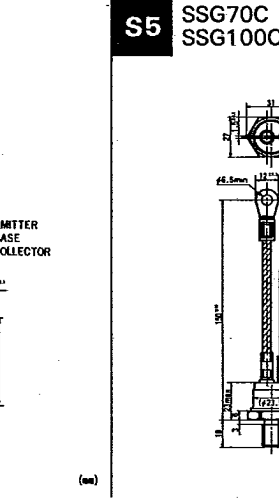
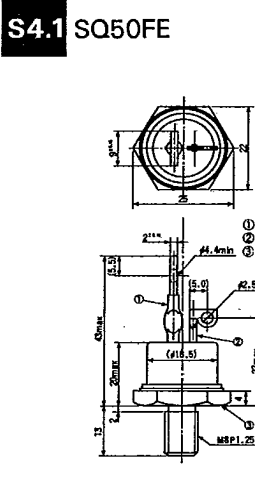
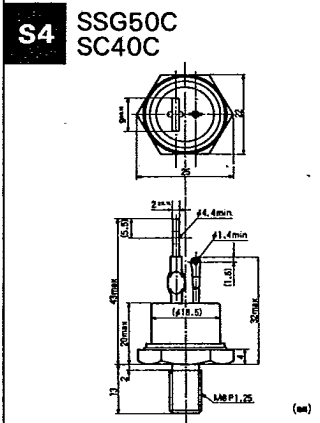
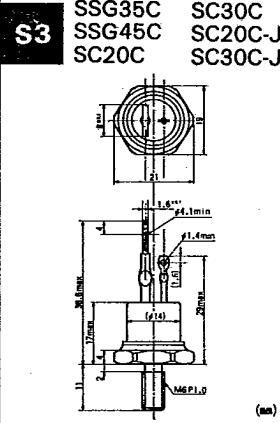
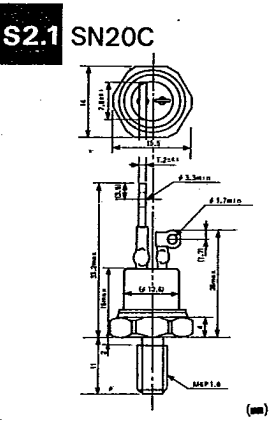
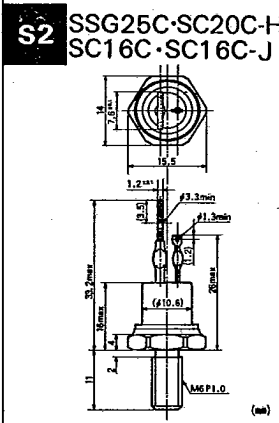
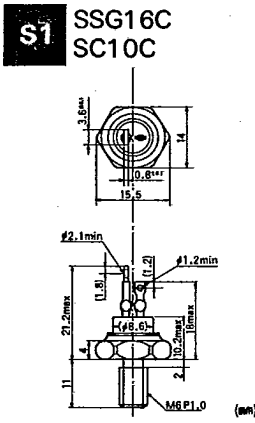

9